



BOX·MARINE, S.A.

ORENSE, 8 PHONE 341 - 455 24 00 TELEX 49578 BOXM-E 28020 MADRID SPAIN

M/V "RUBI" 7,150 DWT
M/V "DIAMANTE" 7,150 DWT
M/V "ZAFIRO" 7,150 DWT



Main particulars

CLASS:

Single decker.
L.R. + 100A1-LMC-UMS.
Strengthened for heavy cargoes.
Grain fitted.
Spanish flag.

CUBIC CAPACITY:

Grain:	Hold no. 1	160,408	cb.ft.
(See note)	Hold no. 2	154,405	cb.ft.
	Total	314,813	cb.ft.
Bale:	Hold no. 1	150,794	cb.ft.
(See note)	Hold no. 2	145,143	cb.ft.
	Total	295,937	cb.ft.

Register: 3,998 G.R.T. - 2,806.6 N.R.T.

BUILT:

January 82 / May 82 / August 83.

DIMENSIONS:

Length overall	104.00 m. - 341' 2.5"
Length b.p.p.	95.40 m. - 313' —
Maximum breadth	16.50 m. - 54' 1.6"
Depth	9.70 m. - 31' 10.0"
Summer draft	7.59 m. - 24' 9.0"
Max. air draft (ballast)	30.50 m. - 100' 1.0"

DEADWEIGHT:

At summer mark. (7.59 m.) - 7,162 Tons
At winter mark. (7.45 m.) - 6,937 Tons

SPEED AND RANGE:

Trial condition speed	13.4 kn.
Service speed	12.5 kn.
Service range (about)	9,000 n.m.

CONSUMPTION:

At sea about	10,500 kg/day I.F.O. 60
	865 kg/day gas oil
At harbour about	750 kg/day gas oil

Dead weight tons. scale

DRAUGHT		DISPLACEMENT		DEAD WEIGHT				TM IMMERSION		DRAUGHT	
		SW	FW	SW	FW	SW	FW	TM	TM		
METRES	FEET	TM	TM	TM	TM	LT	LT	CM	INCHES	FEET	METRES
			10000	8400		8200	8000	14.8	37.0		
				8200		8000	7800	14.7			
			10000	8400		8200	8000	14.6	36.5		
				8200		8000	7800	14.5			
8			9500	7800		7600	7400	14.4	38.0		8
				7600		7400	7200	14.3			
			9500	7800		7600	7400	14.2	35.5		
				7600		7400	7200	14.1			
			9000	7000		6800	6600	14.0	35.0		
				6800		6600	6400	13.9			
			8500	6800		6600	6400	13.8	34.5		
				6600		6400	6200	13.7			
7			8000	6200		6000	5800	13.6	34.0		7
				6000		5800	5600	13.5			
			8000	6200		6000	5800	13.4	33.5		
				6000		5800	5600	13.3			
			7500	5800		5600	5400	13.2	33.0		
				5600		5400	5200	13.1			
			7000	5200		5000	4800	13.0	32.5		6
				5000		4800	4600	12.9			
			7000	5200		5000	4800	12.8	32.0		
				5000		4800	4600	12.7			
			6500	4800		4600	4400	12.6	31.5		
				4600		4400	4200	12.5			
			6000	4200		4000	3800	12.4	31.0		
				4000		3800	3600	12.3			
			5500	3600		3400					5
				3600		3400					

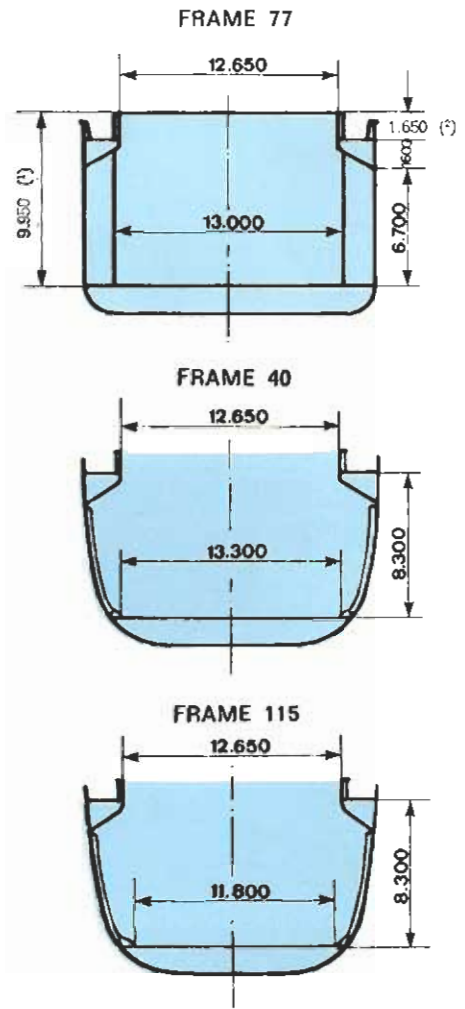
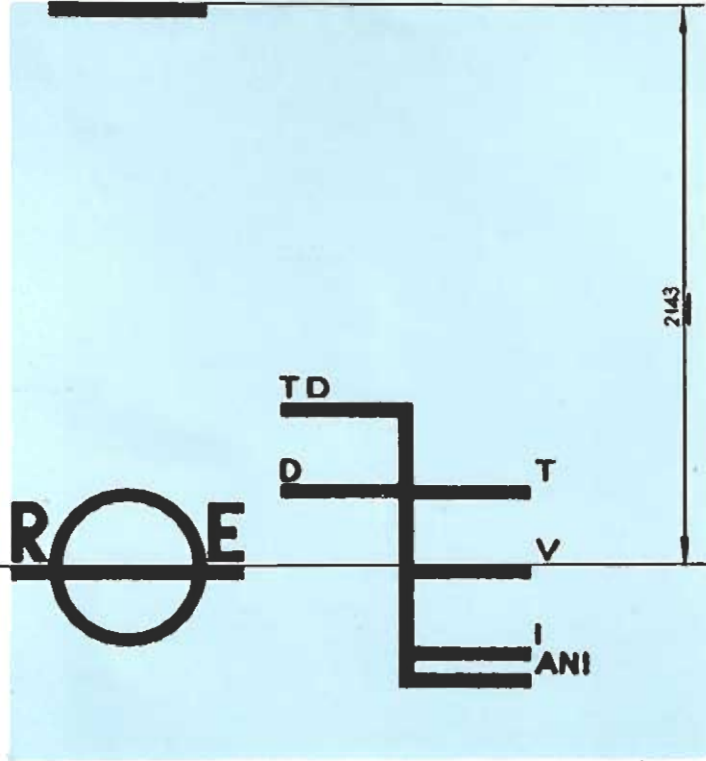

NOTES

- (1) In M.V. ZAFIRO: 9.920
- (2) In M.V. ZAFIRO: 1.620

GENERAL DESCRIPTION

MAIN ENGINE

In M/V RUBI and DIAMANTE:
Deutz RBV 12M-350 Four stroke-turbocharged.
Direct reversible.

Continuous output 4,000 BHP
Speed 430 r.p.m.

Bridge control.

In M/V ZAFIRO:
Deutz RBV 8M-540, 4,000 BHP at 600 r.p.m.

AUXILIARY ENGINES-GENERATOR SETS

In M/V RUBI and DIAMANTE:
3 Caterpillar 3408-TA of 335 BHP at 1,500 r.p.m.
3 Generators of 214 Kw, 270 Kva, at 1,500 r.p.m.

In M/V ZAFIRO:
3 Deutz BA 6M-816U of 379 BHP at 1,500 r.p.m.
3 Generators of 214 Kw, 270 Kva, at 1,500 r.p.m.

AUXILIARY EQUIPMENT

- One (1) combined exhaust/oil fired boiler 500/500 kg per hour at 6.5 kg.sq.cm. steam production. Two (2) feed pumps for the boiler.
- Two (2) hydrofor plants for the sanitary system. One for SW and one for FW. Separate tank with heating coil for hot water.
- Two (2) engine room fans each 30,000 c.m/h. One suction fan for the purifiers area.
- One bilge water separator 10 T/h.
- Workshop; workshop machines; spares to class, tools, lifting gear, etc., to normal good standard shipyard practice.
- SW pumps with impeller and case of bronze. Stainless steel shaft.
- FW pumps with impeller of bronze and case of cast iron.
- One (1) FW generator, 3 Tons/24 hours.
- Three (3) purifiers: One selfcleaning for HFO with steam heater; One non-selfcleaning for D.O.; One non-selfcleaning for L.O.
- FO system for HFO 600 Sec. Redwood I at 100° F. Separate FO system for light FO.
- Bilge system according to Rules. Piping to be lead through DB tanks.
- Fire-fighting system according to Rules.
- Ballast system arranged as follows: Two main through DB tanks, one each side, with submerged valves hydraulically and remotely controlled from E.R. Two (2) centrifugal ballast pumps, each 200 T/h. at 20 m.w.c.

DECK MACHINERY

Windlass: 42 mm U3.
Capstan: 5 Tons at 20 M/min.
Steering gear: Temfjord 18M 300 of 18T.

COMMUNICATION AND NAUTICAL EQUIPMENT

- One radio transmitter.
- One radio receiver.
- One radio direction finder.
- One radio telephone.
- One VHF set.
- One emergency radio for life boats.
- One gyrocompass.
- One autopilot.
- One radar.
- One echosounder.
- One electric log line (Sagem).
- One satellite navigator.

ACCOMMODATION

- 22 crew in single cabins plus hospital, owner cabin, etc.

CARGO GEAR

- One electrohydraulic crane of 8 Tons at 16 m.
- Two derricks of 5 Tons at 17.38 m.

HATCH COVER

- Steel hatch covers McGregor single pull type strengthened for 1.36 Tons/sq.m. cargo on top. The dimension of each is 26 x 12.65 m.

NOTE AT CARGO CAPACITY

In M/V ZAFIRO only:

Total cubic capacity in cb.ft.:

Grain hold No. 1 160,044 cb.ft.
Grain hold No. 2 154,041 cb.ft.

Total 314,085 cb.ft.

Bale hold No. 1 150,430 cb.ft.
Bale hold No. 2 144,779 cb.ft.

Total 295,209 cb.ft.

TANKS CAPACITY

BALLAST	Tons	CMB
Fore peak	209.80	204.70
Fore deep tank	166.00	162.00
Nr. 1 DB port	149.85	146.20
Nr. 1 DB starboard	149.85	146.20
Nr. 2 DB port	102.55	100.05
Nr. 2 DB starboard	102.55	100.05
Nr. 3 DB port	113.00	110.25
Nr. 3 DB starboard	113.00	110.25
Nr. 4 DB port	73.80	72.05
Nr. 4 DB starboard	73.80	72.05
Central deep tank port	149.35	145.70
Central deep tank starboard	149.35	145.70
Central deep tank port	149.35	145.70
Central deep tank starboard	149.35	145.70
Aft peak	167.39	163.31
	2,018.99	1,969.91

OIL

Oil storage tank	5.42	6.03
Dirty oil tank	7.20	8.00
	12.62	14.03

FUEL OIL

	Tons	CMB
Nr. DB central	114.36	124.30
Nr. DB central	125.34	136.24
Nr. DB central	126.74	137.76
DB overflow tank	8.50	9.24
Storage tank	23.05	25.06
Settling tank	13.75	14.95
	411.74	447.55

GAS OIL

Settling tank port	33.60	40.00
DB storage tank starboard	7.30	8.69
DB storage tank port	19.07	22.70
Daily service tank port	6.10	7.25
Daily service tank port	6.30	7.50
	72.37	86.14

FRESH WATER

Fresh water tank port	11.95	11.95
Fresh water tank starboard	11.95	11.95
Drinking water tank port	37.96	37.96
Drinking water tank starboard	37.96	37.96
	99.82	99.82